

T-HC Series Horizontal Cartoner



Robotic Packaging Solutions



Horizontal Cartoner- Typical Configuration

The Horizontal Cartoner is the ideal flexible system for loading single or multiple flow wrapped pharmaceuticals, food products or medical devices into cartons with high throughputs or in multiple formats.

Designed to perform the functions of carton erecting, product collation, product loading, leaflet insertion, and carton closing by means of tuck closure or hot melt glue all within a single machine footprint. The system is ideal for facilities that require continuous operation with minimal operator intervention.

Features and Benefits

- Easy access for line clearance, cleaning and maintenance
- Large colour touch screen HMI
- Standard components for mechanics and drives
- Rapid size change with no tooling required
- Gentle product handling with servo control
- Quiet operation under continuous high speeds
- Extended magazine provides uninterrupted operation
- Optional integration of a labeller and/or data printer



Technical Information

Base Machine Modules	<ul style="list-style-type: none"> - Control Panel – AISI 304L, IP66 - 2-Axis Delta Robot - Stainless Steel Robot Head And Arms - No Calibration Required
Machine Frame	<ul style="list-style-type: none"> - Fabricated Stainless Steel with Polished Finish - Anti-Vibration Support Structure - GMP Features For Easy Cleaning
Control System	<ul style="list-style-type: none"> - Allen Bradley, Schneider or Siemens Options
Software Functions	<ul style="list-style-type: none"> - Format Control/Format Settings List/Data Location - Control Of The Conveyor Speeds By TCP/IP - Upstream/Downstream Signal Connectivity
Safety	<ul style="list-style-type: none"> - Interlocked Doors - E-Stop On The Main Operator Panel - Remote Panel E-Stop - Power Isolator With LOTO
Pneumatics	<ul style="list-style-type: none"> - Festo, SMC or Bosch Rexroth

Operator Interface

HMI Display	<ul style="list-style-type: none"> - Large Colour Touch Screen - HMI Mounted on Articulated Rotary Arm with Horizontal Adjustment
Operator Controls	<ul style="list-style-type: none"> - Alarms, Warnings, Prompt Messages - I/O Status Check - Machine State (Stop, Ready, Running, Alarm) - Counters (Throughput, Batch Count, Rejects) - Password Protected Local Access Levels - Maintenance Intervals Displayed on HMI - Machine Cycle Count

Service Specifications

Electrical Supply	- 400v, 50Hz, 3 Phase, Neutral + Earth
Compressed Air	- 6 Bar Clean Dry Compressed Air
Control Voltage	- 24 V DC (Internal)



2-Axis Robotic Side Loading of Product



Carton Take Down Module

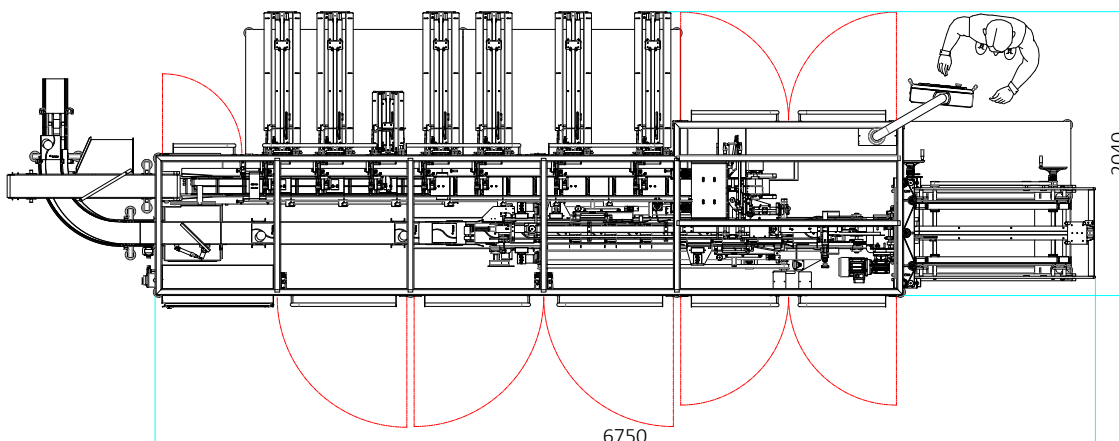

2D Layout of Horizontal Cartoner - Typical Configuration



Customised Engineering & Integration



24/7 Technical Support